

Advancing the Science of Sealing™

Expansion Joints Technical Manual



Garlock
SEALING TECHNOLOGIES®

an EnPro Industries company

Garlock Expansion Joints

In service to world industries since 1887, Garlock has led the production and implementation of the latest Expansion Joint Technology for over fifty years.

Just a few of the “firsts” developed by Garlock:

- Development of high temperature elastomers to the levels now considered the industry standard
- Developing the patented construction with bonded rectangular body rings
- Creation of fused FEP liners designed specifically for chemical use
- Abilities to combine fabric, FEP and elastomers effectively
- Design of spool type joints to over 10 foot (120" or 3m) I.D.'s
- Development of the flowing arch design
- Fully tested and field engineered. All Garlock expansion joint styles have been rigorously lab and field-tested, and engineered to ensure long life and reliable service.



Contents

Expansion Joint Styles

Expansion Joint Selection.....	B-2
GUARDIAN® 200 and 200HP.....	B-3
Styles 204 and 204HP	B-4
Style 204EVS.....	B-5
GUARDIAN® 306 EZ-FLO®	B-6
Style 206 EZ-FLO®	B-7
Style 104GS.....	B-8
Styles 214 and 215 Flexible Couplings.....	B-9
Styles 207 and 208	B-11
GARFLEX® 8100.....	B-12
Style 9394.....	B-13
Style 8400 Flue Ducts.....	B-14
Style 8400-HT	B-15
Style 8420 Split.....	B-16
Navy & Coast Guard Approved Styles	B-17

Engineering Data

Technical Data	B-18
Types of Expansion Joints	B-20
Expansion Joint Components	B-21
Types of Pipe Movements.....	B-22
Properties of Elastomers.....	B-23
Temperature Ratings.....	B-23
Expansion Joint Installation	B-24
Troubleshooting	B-25
Weights	B-26
Application Data Form	B-27

Introduction

An expansion joint is a specially engineered product inserted in a rigid piping system to achieve one or more of the following:

- Absorb movement
- Relieve system strain due to thermal change, load stress, pumping surges, wear or settling
- Reduce mechanical noise
- Compensate for misalignment
- Eliminate electrolysis between dissimilar metals

At Garlock, the range of our engineering emphasis extends from the selection of the fabric used for reinforcement to the choice of materials used in actual expansion joint construction.

Rigid laboratory and field tests of Garlock expansion joints are what back up our assurances of long life and reliable service. An important word on safety: all Garlock expansion joints carry safety ratings **exceeding** product specifications in such areas as pressure and movement.

Garlock nonmetallic expansion joints and flexible couplings are ideally suited for hundreds of applications in a wide range of industries, including:

- Power generating stations
- Pulp and paper
- Chemical and industrial process piping
- Waste water and sewage disposal
- Marine applications
- Heating, ventilating and air conditioning

Joint Selection

To select the proper expansion joint, consider:

- Pipe size
- Pumped medium: type of liquid, gas, or vapor in system
- Temperature range
- Pressure/vacuum range
- Movements needed
- Environment: degree of exposure to:
 - Weathering
 - Sunlight
 - Liquids
 - Gases
 - Vapors
 - Oil
 - Open flame
 - Chemicals
 - Other
- Installed face-to-face dimensions
- Degree of pipe misalignment
- Drilling: if other than standard 125 lb. ANSI, determine:
 - Flange O.D.
 - Bolt circle
 - Number of bolt holes
 - Diameter of hole
- Need for retaining rings
- Need for control units
 - Recommended for use with most expansion joints
 - Must be used in cases of insufficient pipe support
- Need for special construction

Garlock Recommendations

	200	200HP	204, 204HP	206	207, 208	214, 215	306	104GS	8100	9394	8400
Standard Piping— High Pressure		★	★	★					★		
Standard Piping— Low Pressure					★			★		★	★
Chemical Piping	★	★				★	★				
Standard Ducts										★	★
Nuclear			★	★	★						
Naval and Coast Guard			★	★					★		

GUARDIAN® 200 and 200HP

Garlock GUARDIAN® 200 expansion joints consist of a chemically-resistant FEP* liner mechanically bonded to an abrupt arch. A chlorobutyl cover and blue protective coating add resistance to environmental effects. (Alternate cover materials available.)

Benefits

- High-density FEP liner reduces permeation and offers optimal chemical resistance
- Mechanically bound liner reduces delamination; no glue to be vulnerable to chemical attack
- High pressure and vacuum resistance ensures suitability for broad range of applications
- Available with GYLON® 3545 gasket face for raised face flange connections

Design

- **Tube**
 - Seamless FEP lining extends to the outer edge of the flange; completely fused to the joint body
 - Abrupt arch design used for maximum movement capabilities

Body

- Chlorobutyl/polyester construction with welded, treated metal body rings for dimensional stability

Cover

- Homogeneous layer of chlorobutyl elastomer is standard
- Elastomer extends to the outside diameter of the flange

Temperature

Max. Temp.

Standard chlorobutyl/polyester+250°F (+120°C)

Chlorobutyl/fiberglass/Kevlar**

with EPDM cover+300°F (+150°C)

Fluoroelastomer w/ fiberglass/Kevlar ..+400°F (+205°C)

* Fluorinated Ethylene Propylene

** Kevlar is a registered trademark of DuPont.

Pressure & Vacuum Rating

	Pipe I.D.		Pressure		Vacuum	
	Inch	mm	psi	bar	in. Hg	mm Hg
GUARDIAN® 200†	2-4	50-100	165	11	29.9	750
	5-12	125-300	140	10	29.9	750
	14	350	85	6	29.9	750
	16-24	400-600	65	5	29.9	750
	26-30	650-750	55	4	29.9	750
GUARDIAN® 200HP†	2-6	50-150	200	14	29.9	750
	8-12	200-300	190	13	29.9	750
	14	350	130	9	29.9	750
	16-20	400-500	110	8	29.9	750
	22-24	550-600	100	7	29.9	750
	26-30	650-750	90	6	29.9	750



Made in the U.S.A.

Movement Capabilities

Please refer to table on pages 18 & 19.

† Higher pressure designs are available. Call Garlock with application details.

Styles 204 and 204HP

Styles 204 and 204HP spool-type expansion joints can be constructed as single- or multiple-arch types. They connect pipe flanges in concentric or eccentric tapers, to join piping of unequal diameters.

Benefits

- Fully lab- and field-tested for long life and exceptional reliability
- Seamless flange face eliminates need for gaskets
- High pressure- and vacuum-resistance increases safety and ensures suitability for wide range of applications
- Can be custom-designed for greater movement capability and easier installation
- Variety of elastomer and fabric combinations meet the demands of temperature, pressure and media

Design

- **Tube**
 - Chlorobutyl resists cracking due to high temperatures, weathering, oxidation and chemicals
 - Abrupt arch configuration provides maximum movement, and pressure and vacuum resistance
 - Seamless tube creates a positive flange seal without gaskets

	Pipe I.D.		Pressure Rating		Vacuum	
	Inch	mm	psi	bar	in. Hg	mm Hg
Style 204†	1/2-4	13-100	165	11	29.9	750
	5-12	125-300	140	10	29.9	750
	14	350	85	6	29.9	750
	16-24	400-600	65	4.5	29.9	750
	26-66	650-1,650	55	3.8	29.9	750
	68-96	1,700-2,400	45	3	29.9	750
	98-108	2,450-2,700	40	2.8	29.9	750
	110-120	2,750-3,000	30	2	29.9	750
Style 204HP†	1/2-4	13-100	200	14	29.9	750
	5-12	125-300	190	13	29.9	750
	14	350	130	9	29.9	750
	16-20	400-500	110	8	29.9	750
	22-24	550-600	100	7	29.9	750
	26-40	650-1,000	90	6	29.9	750
	42-66	1,050-1,650	80	5.5	29.9	750
	68-96	1,700-2,400	70	5	29.9	750
	98-108	2,450-2,700	60	4	29.9	750
110-120	2,750-3,000	50	3.5	29.9	750	

† Higher pressure designs are available. Call Garlock with application details and to inquire about larger sizes.

Please refer to table on pages 18 & 19.



- **Body**
 - Chlorobutyl/polyester construction with welded, treated metal body rings for dimensional stability
- **Cover**
 - Chlorobutyl extends to outside flange diameter
 - Durable coating resists weathering and oxidation

Special Liner and Cover Materials

- Hypalon**
- Nitrile
- Natural Gum
- EPDM
- Neoprene
- FDA materials available

Temperature

Max. Temp.

Chlorobutyl/Polyester w/Natural Gum .+180°F (82°C)
 Standard chlorobutyl/polyester +250°F (+120°C)
 Chlorobutyl/fiberglass/Kevlar**
 with EPDM tube and cover +300°F (+150°C)
 Fluoroelastomer w/ fiberglass/Kevlar +400°F
 (+205°C)

** Kevlar is a registered trademark of DuPont; Hypalon is a registered trademark of DuPont Dow Elastomers.

Optional Configurations

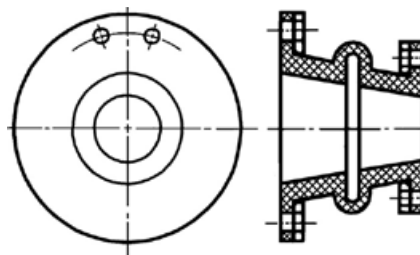

Concentric Tapered

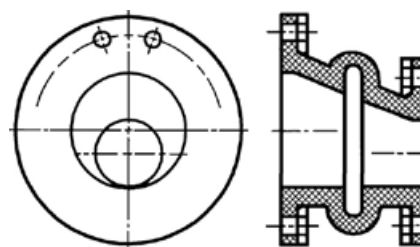

Eccentric Tapered

Style 204EVS

(Extreme Vacuum Service)

Benefits

- Arch support ring reduces risk of arch collapse during vacuum service and system start-up
- Single open arch provides full range of movement
- The chlorobutyl cover and sealed bolt holes help to eliminate O₂ intrusion
- Unique combination of rubber and fabric reinforcement, combined with metal body rings, ensure best adhesion and dimensional stability
- Offset configurations available to accommodate misaligned piping and equipment, eliminating realignment
- Ideal for the dual challenges of extreme vacuum and aggressive systems dynamics
- Condensate pump applications with less than ideal support and/or long cantilevered pipe runs



Specifications

Temperature, max.	180°F (82°C)
Pressure, max.	55 psig (3.8 bar)
Vacuum:	29.9" Hg
Burst Rating:	3:1
Available sizes:	14" through 48" ID

Contact Garlock Customer Service for pricing and delivery. Use of control units with compression sleeves are recommended.

Movement Capabilities

Pipe I.D.		Comp.		Lateral		Elong.	
Inch	mm	Inch	mm	Inch	mm	Inch	mm
14-18	350-450	3/4	19	1/2	12	3/8	9
20-24	500-600	7/8	22	1/2	12	7/16	11
26-40	650-1,000	1	25	1/2	12	1/2	12
42-48	1,050-1,200	1-1/8	29	1/2	12	1/2	12

* Movements listed are non-concurrent. For concurrent movements, contact Garlock.

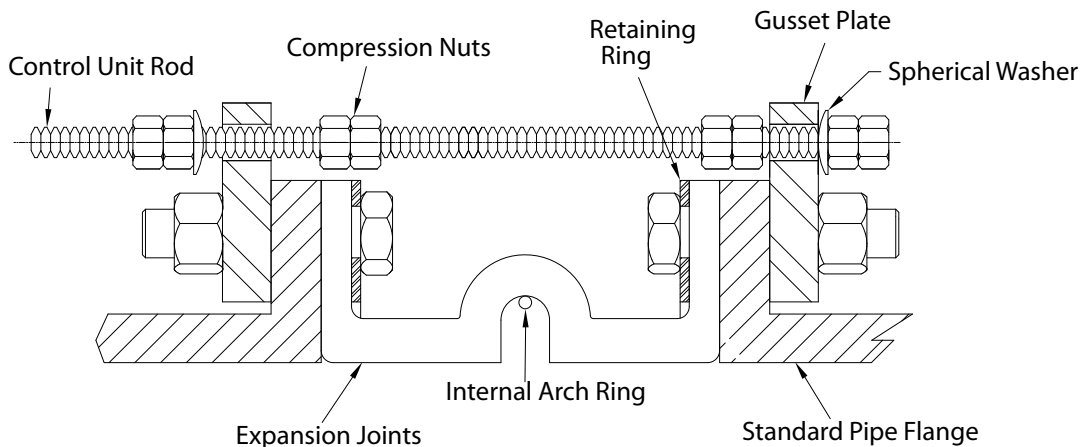

GUARDIAN® 306 EZ-FLO®

Garlock GUARDIAN® 306 EZ-FLO® spool-type expansion joints feature an FEP lining that is fused to the body of the expansion joint.

This product is designed for the chemical processing and pulp & paper industries, where its ability to resist corrosive attack at normal or elevated temperatures and pressures is unequaled.

Benefits

- FEP liner is non-contaminating and suits a wide range of applications
- Flowing arch design prevents media buildup and reduces turbulence and vibration
- 250 psig (17 bar) pressure rating ensures longer service life and consolidates inventory
- Liner extends to outer diameter of flange to prevent chemical attack on expansion joint flanges
- Mechanically bonded liner resists delamination

Design

- **Tube**
 - Seamless FEP lining extends to the outer edge of the flange; completely fused to the expansion joint body
 - Incorporates a flowing arch design to resist product build-up
- **Body**
 - Impregnated nylon tire cord fabric cross-wrapped in bias-ply construction
- **Cover**
 - Homogeneous layer of chlorobutyl elastomer extends to the outside edge of the flange
 - Coated with a weather-resistant protectant
- **Special Designs**
 - Non-standard face-to-face dimensions (pressure / vacuum ratings may be affected)
 - Non-standard drill patterns
 - Blind flanges (no drilling)
 - Lightweight designs available for low pressure and non-metallic pipe applications
 - Available with GYLON® 3545 gasket face for raised face flange connections



Pressure and Vacuum Rating*

	Pipe I.D.		Pressure		Vacuum	
	Inch	mm	psi	bar	in. Hg	mm Hg
Style 306	3-10	75-250	250	17	26	650
EZ-FLO®	12	300	250	17	17	425
	14	350	130	9	17	425
	16-20	400-500	110	8	15	375

* Pressure and vacuum ratings are for neutral FF dimensions only.

Consult Garlock for alternate sizes and corresponding pressure/vacuum ratings. Consult Garlock for larger sizes. Metric sizes available on request.

Listed pressure ratings are based on a 4:1 safety factor at max. design temp.

Movement Capabilities

Please refer to table on pages 18 & 19.

Temperature

	Max. Temp.
Chlorobutyl/nylon tire cord.....	+250°F (+120°C)
Chlorobutyl/Kevlar** tire cord with EPDM cover	+300°F (+150°C)

** Kevlar is a registered trademark of DuPont.

WARNING:

Properties/applications shown throughout this brochure are typical. Your specific application should not be undertaken without independent study and evaluation for suitability. For specific application recommendations consult Garlock. Failure to select the proper sealing products could result in property damage and/or serious personal injury.

Performance data published in this brochure has been developed from field testing, customer field reports and/or in-house testing.

While the utmost care has been used in compiling this brochure, we assume no responsibility for errors. Specifications subject to change without notice. This edition cancels all previous issues. Subject to change without notice.

GARLOCK is a registered trademark for packings, seals, gaskets, and other products of Garlock.

Style 206 EZ-FLO®

EZ-FLO® expansion joints contain a single wide flowing arch, eliminating the need for filled arches on slurry services. Garlock EZ-FLO® expansion joints have successfully served all major industries, including pulp and paper, steel, waste and water, HVAC, power generation, chemical, petrochemical and marine.

Benefits

- Self-flushing design eliminates media buildup and reduces fluid turbulence
- High pressure- and vacuum-resistance ensures longer life and reduces inventory requirements
- Lightweight design installs easily, costs less to ship

Design

- **Tube**
 - Standard chlorobutyl liner extends to outer edge of the flange for excellent chemical resistance
 - Flowing arch design adds pressure resistance and reduces product buildup
- **Body**
 - Rubber impregnated tire cord and polyester cross-wrapped in bias-ply construction
- **Cover**
 - Homogeneous layer of chlorobutyl elastomer extends to the outside edge of the flange
 - Coated with a weather-resistant protectant

Special Liner* and Cover Materials

- Neoprene
- EPDM
- Hypalon**
- FDA materials available
- Nitrile
- Natural Gum

Temperature

	Max. Temp.
Chlorobutyl/nylon tire cord w/natural gum	+180°F (+82°C)
Chlorobutyl/nylon tire cord	+250°F (+120°C)
Chlorobutyl/Kevlar** tire cord/ EPDM tube and cover	+300°F (+150°C)

* When EZ-FLO® expansion joints are furnished with special liners, temperature ratings may change.

** Kevlar is a registered trademark of DuPont; Hypalon is a registered trademark of DuPont Dow Elastomers.



Pressure and Vacuum Rating

Pipe Size I.D.		Pressure		Vacuum	
Inches	mm	psi	bar	In. Hg	mm Hg
2-10	50-250	250	17	26	650
12	300	250	17	12	300
14	350	130	9	12	300
16-20	400-500	110	8	12	300
22-24	550-600	100	7	12	300
26-40	650-1000	90	6	12	300
42-66	1050-1650	80	5.5	12	300
68-96	1700-2400	70	5	12	300
98-108	2450-2700	60	4	12	300
110-120	2750-3000	50	3.5	12	300

Notes:

1. See pages B-6 and B-7 for temperature and pressure ratings of GUARDIAN® 306 EZ-FLO® expansion joint.
2. Pressure and vacuum ratings at neutral FF dimension. Extended face-to-face dimensions result in reduced pressure and vacuum ratings for Style 206 EZ-FLO® expansion joints.

Movement Capabilities

Please refer to table on pages 18 & 19.

Control Units

Control units must be used to protect expansion joints from excessive movement if piping is not properly anchored. See page B-21 for information.

Style 104GS

General service elastomeric expansion joint

General service expansion joints must withstand a variety of different operating conditions across multiple industries. The 104GS from Garlock is designed to handle these most common requirements, and more. Although competitively priced, the 104GS has been rigorously tested to insure it provides the same quality and consistency you expect from Garlock products.

Benefits & Design

- The versatility of the neoprene tube **1** and cover **4** make the 104GS ideally suited for most general service industrial applications.
- Reinforcement materials of nylon fabric **5** combined with carbon steel body wire **3** and support rings **2** allow the 104GS to withstand significant operating pressures and 26" Hg vacuum for all sizes.
- The wide, single arch **6** design allows for greater movements and helps to reduce the affects of moderate sediment transfer.
- Available in 2" thru 36" and sold complete **7** with galvanized carbon steel retaining rings simplifying the order process.



Specifications - 200°F Maximum Temperature Rating

Expansion Joint				Application Data				Movement Ratings							
Size I.D.		Face-to-Face		Pressure		Vacuum		Compression		Lateral		Elongation		Angular Degrees	Tortional Degrees
Inch	mm	Inch	mm	psi	bar	Inch Hg	mm Hg	Inch	mm	Inch	mm	Inch	mm		
2	50	6	150	195	13	26	660	1-1/4	32	3/4	19	1/2	13	10	3
3	75	6	150	195	13	26	660	1-1/4	32	3/4	19	1/2	13	8	3
4	100	6	150	195	13	26	660	1-1/4	32	3/4	19	1/2	13	6	3
5	125	6	150	165	11	26	660	1-3/8	35	1	25	5/8	16	8	3
6	150	6	150	165	11	26	660	1-3/8	35	1	25	5/8	16	7	3
8	200	6	150	165	11	26	660	1-3/8	35	1	25	5/8	16	5	3
10	250	8	200	165	11	26	660	1-3/8	35	1	25	5/8	16	5	3
12	300	8	200	165	11	26	660	1-1/2	38	1	25	3/4	19	5	3
14	350	8	200	100	7	26	660	1-1/2	38	1	25	3/4	19	4	2
16	400	8	200	75	5	26	660	1-1/2	38	1	25	3/4	19	4	2
18	450	8	200	75	5	26	660	1-1/2	38	1	25	3/4	19	3	1
20	500	8	200	75	5	26	660	1-1/2	38	1	25	3/4	19	3	1
24	600	10	250	75	5	26	660	1-3/4	44	1	25	1	25	4	1
30	750	10	250	75	5	26	660	1-3/4	44	1	25	1	25	2-1/2	1
36	900	10	250	75	5	26	660	1-3/4	44	1	25	1	25	2	1

Expansion Joint Size I.D.		ANSI Class 150 Flange Drilling						No. of Bolt Holes	Spring Rates						Bolt Torque Ft-Lbs
		OD		Bolt Circle		Bolt Hole Diameter			Compression		Lateral		Elongation		
		Inch	mm	Inch	mm	Inch	mm		lb/Inch	kg/mm	lb/Inch	kg/mm	lb/Inch	kg/mm	
2	50	6	152	4-3/4	121	3/4	19	4	450	18	340	13	560	22	40
3	75	7-1/2	191	6	152	3/4	19	4	670	26	500	20	828	15	65
4	100	9	229	7-1/2	191	3/4	19	8	900	35	730	29	1104	20	45
5	125	10	254	8-1/2	216	7/8	22	8	1120	44	900	35	1376	25	50
6	150	11	279	9-1/2	241	7/8	22	8	1400	55	1060	42	1652	30	55
8	200	13-1/2	343	11-3/4	298	7/8	22	8	1510	59	1180	46	1837	33	85
10	250	16	406	14-1/4	362	1	25	12	1900	75	1460	57	2296	41	80
12	300	19	483	17	432	1	25	12	2300	91	1740	69	2755	50	115
14	350	21	533	18-3/4	476	1-1/8	29	12	2010	79	1570	62	2755	50	145
16	400	23-1/2	597	21-1/4	540	1-1/8	29	16	2300	91	1740	69	2755	50	135
18	450	25	635	22-3/4	578	1-1/4	32	16	2570	101	1960	77	3101	56	140
20	500	27-1/2	699	25	635	1-1/4	32	20	2860	113	2180	86	3440	62	135
24	600	32	813	29-1/2	749	1-3/8	35	20	3420	135	2630	104	4130	74	190
30	750	38-3/4	985	36	915	1-3/8	35	28	3532	63	4150	74	4594	82	180
36	900	46	1170	42-3/4	1090	1-5/8	42	32	4240	76	6330	113	5510	98	235

Pressure ratings are based on a minimum 3 to 1 safety factor at maximum design temperature.

Styles 214 and 215

These PTFE concentric spool-type flexible couplings are designed to reduce noise and compensate for expansion, contraction and minor piping misalignment in chemical processing, air conditioning and heating systems.

Style 214

- Two convolutions
- Temperature: -100°F (-70°C) to +450°F (+230°C)
Pressure: To 178 psig (12 bar),
Full vacuum to +350°F (+180°C)

Style 215

- Three convolutions
- Temperature: -100°F (-70°C) to +450°F (+230°C)
Pressure: To 132 psig (9 bar),
Full vacuum to +180°F (+80°C)

Benefits

- Convolution shape provides extra-long flex life at high temperatures
- Proprietary contour molding process ensures consistent wall thickness for blowout resistance
- PTFE body withstands corrosion, water, steam, and most chemicals and gases
- Preset restriction bolts prevent over-extension
- Available silicone-free

Design

- Complete assembly includes fluorocarbon resin PTFE body, plated ductile iron flanges, polyethylene-covered restriction bolts and corrosion-resistant reinforcing rings
- Standard sizes from 1" (25 mm) through 8" (200 mm) pipe I.D.



Pressure and Vacuum Rating

Garlock PTFE expansion joints and couplings have pressure ratings high enough to handle most applications. As the pipe size gets larger, Garlock increases the bellows thickness and the strength of the reinforcing rings to compensate for the change in internal forces. This permits the same high pressure rating for all sizes.

Temperature		214 Pressure		215 Pressure	
		psi	bar	psi	bar
50°F	10°C	178	12	132	9
100°F	50°C	165	11	120	8
150°F	65°C	150	10	103	7
200°F	90°C	130	9	90	6
250°F	120°C	110	8	75	5
300°F	150°C	92	6	60	4
350°F	180°C	78	5	50	3.5
400°F	205°C	65	4.5	42	3
450°F	230°C	60	4	35	2

WARNING:

Properties/applications shown throughout this brochure are typical. Your specific application should not be undertaken without independent study and evaluation for suitability. For specific application recommendations consult Garlock. Failure to select the proper sealing products could result in property damage and/or serious personal injury.

Performance data published in this brochure has been developed from field testing, customer field reports and/or in-house testing.

While the utmost care has been used in compiling this brochure, we assume no responsibility for errors. Specifications subject to change without notice. This edition cancels all previous issues. Subject to change without notice.

GARLOCK is a registered trademark for packings, seals, gaskets, and other products of Garlock.

Movement Capabilities

Style 214 PTFE Flexible Couplings

Pipe Size (Inches)	1	1-1/2	2	2-1/2	3	4	5	6	8
Nominal Installed Face to-Face	1-3/8	1-3/8	1-9/16	2-1/4	2-1/4	2-5/8	3-1/4	2-3/4	4
Max. Restriction Bolt Setting	1-1/4	1-5/16	1-15/32	2-7/32	2-1/4	2-23/32	3-5/16	2-3/4	4
Max. Axial Movement + or -	1/4	1/4	1/4	5/16	3/8	1/2	1/2	1/2	1/2
Max. Transverse Deflection, + or -*	1/8	1/8	1/8	1/8	3/16	1/4	1/4	1/4	1/4

Maximum angular movement approximately 7°.

* Based on unit being in normal installed position with no axial movement or angular deflection.

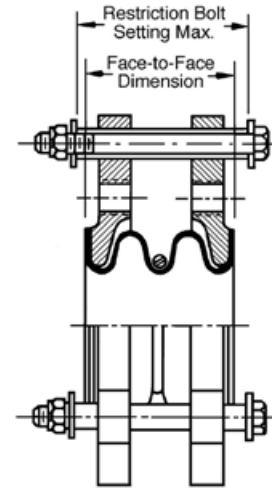

Style 215 PTFE Flexible Couplings

Pipe Size (Inches)	1	1-1/2	2	2-1/2	3	4	5	6	8
Nominal Installed Face to-Face	1-3/4	2	2-3/4	3-3/16	3-5/8	3-5/8	4	4	6
Max. Restriction Bolt Setting	1-7/8	2-5/32	3-5/32	3-9/16	4-1/4	4-1/4	4-9/16	4-5/8	6-5/8
Max. Axial Movement + or -	1/2	1/2	3/4	3/4	1	1	1	1-1/8	1-1/8
Max. Transverse Deflection, + or -*	1/4	1/4	3/8	3/8	1/2	1/2	1/2	9/16	9/16

Maximum angular movement approximately 14°.

* Based on unit being in normal installed position with no axial movement or angular deflection.

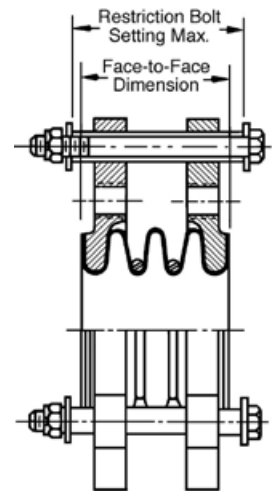

PTFE Control Units and Flanges

All PTFE joints and couplings are furnished with ductile iron flanges and control units ready for immediate installation on the job site. Flanges in other alloys are available by special order.

Flanges are protected to resist atmosphere corrosion and are tapped to 150 lbs. ANSI Standard drilling.

Control units are assembled with flanges to prevent joints from excessive axial elongation. They are designed to accept the static pressure thrust in the piping system.

Tie rods are set at the factory at the maximum face-to-face working limits, with lock nuts as insurance against overextension of the expansion joint. The tie rods are covered with polyethylene to eliminate metal-to-metal contact between the rods and flanges—the most frequent cause of noise transmission and electrolysis.

Flange Dimensions and Drilling

Pipe Size (Inches)	1	1-1/2	2	2-1/2	3	4	5	6	8
Flange Dimensions									
Outside Diameter	5-13/16	6-11/16	7-7/16	8-7/16	9-3/16	10-11/16	11-11/16	13-1/4	15-3/4
Thickness	3/8	3/8	1/2	5/6	5/8	11/16	11/16	11/16	11/16
ANSI Std. Drilling									
Bolt Circle Dia.	3-1/8	3-7/8	4-3/4	5-1/2	6	7-1/2	8-1/2	9-1/2	11-3/4
No. Bolt Holes	4	4	4	4	4	8	8	8	8
Bolt Hole Thread	1/2-13	1/2-13	5/8-11	5/8-11	5/8-11	5/8-11	3/4-10	3/4-10	3/4-10

* Special order only

Styles 207 and 208

Styles 207 and 208 are U-type expansion joints constructed of specialty rubber and fabric. Available in round or rectangular configurations, they are often used as flexible connectors between a turbine and condenser, or other shorter full face applications.

Style 207

- Internally flanged for full vacuum and low pressure applications
- Temperature: To +250°F (+120°C)*
Pressure: 29.9"Hg to 15 psig (1.0 bar)

Style 208



- Externally flanged, primarily for vacuum service
- Temperature: To +250°F (+120°C)*
Pressure: 29.9"Hg to 25 psig (1.7 bar)
- Available in very narrow face-to-face dimensions; staggered drilling facilitates installation
- Also recommended to reduce vibration and noise on lightweight piping, i.e. those carrying coal-laden air to pulverized coal burners

Note: For recommendations for specific applications, including range of available elastomers, consult Garlock.

Alternate Tube and Cover Materials

- Neoprene
- Nitrile
- Hypalon*
- Natural Gum
- EPDM
- Viton*

Movement Capabilities

	Type Movement	Pipe I.D.		Movement	
		Inch	mm	Inch	mm
	Compression	2-20	50-500	1/2	12
		22 & Up	550 & Up	3/4	19
	Elongation	2-20	50-500	1/4	6
		22 & Up	550 & Up	1/4	6
	Lateral	2-20	50-500	1/2	12
		22 & Up	550 & Up	1/2	12

* For higher temperature capabilities, consult Garlock.

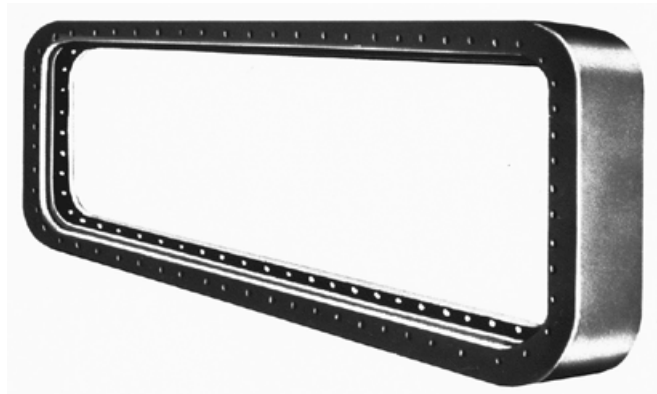

WARNING:

Properties/applications shown throughout this brochure are typical. Your specific application should not be undertaken without independent study and evaluation for suitability. For specific application recommendations consult Garlock. Failure to select the proper sealing products could result in property damage and/or serious personal injury.

Performance data published in this brochure has been developed from field testing, customer field reports and/or in-house testing.

While the utmost care has been used in compiling this brochure, we assume no responsibility for errors. Specifications subject to change without notice. This edition cancels all previous issues. Subject to change without notice.

GARLOCK is a registered trademark for packings, seals, gaskets, and other products of Garlock.

GARFLEX® 8100

GARFLEX® expansion joints feature rugged yet flexible nylon cord reinforcement in a molded, spherical bellows design that ensures an exceptional burst pressure rating. The streamlined flowing arch design reduces turbulence and allows smooth, quiet flow—no need to fill the arch and restrict its movement.

Benefits

- Flowing arch design prevents sediment buildup and reduces turbulence
- Floating flanges can be rotated to accommodate torsional misalignment
- Molded spherical bellows accommodate up to one inch of axial movement and transverse deflection
- Nylon-reinforced nitrile tube earns high pressure rating without sacrificing flexibility; resists most hydrocarbons, oils and gasoline

Design

- **Tube**
 - Nitrile bellows with rugged nylon tire cord reinforcement ensure strength yet flexibility
 - Incorporates a flowing arch design to eliminate product buildup
- **Cover**
 - Homogeneous layer of neoprene coated with a protectant withstands weathering and ozone
- **Flanges**
 - Metal coating flanges with rust resistant coating

Note:

Style 8100 expansion joints are supplied with rotating flanges drilled to ANSI Class 150# specifications. Can be installed against raised face pipe flanges.

Bellow Sizes

	Nominal F-F (in.)	Nominal Bellow I.D. (inch)									
		2	2.5	3	4	5	6	8	10	12	
Series 50	5	■	■	■	■	■	■	■	■	■	■
Series 60	6	■	■	■	■	■	■	■	NA	NA	
Series 80	8	NA	NA	NA	NA	NA	NA	NA	■	■	

NA = Not available



Temperature / Pressure Nylon-Reinforced Nitrile

Operating Temperature		Pressure	
°F	°C	psi	bar
To 120°F	To 50°C	232	16
120°F to 160°F	50°C to 70°C	174	12
160°F to 195°F	70°C to 90°C	139	9.5
195°F to 210°F	90°C to 100°C	70	5
210°F to 230°F	100°C to 110°C	25	1.7

Vacuum Rating* – Nitrile

Pipe I.D.		Vacuum	
Inch	mm	in. Hg	mm Hg
2 to 2-1/2	50 to 63	23	575
3	75	20	500
4	100	17	425
5 to 6	125 to 150	11	275
8	200	8	200
10 to 12	250 to 300	5	125

* At nominal FF dimensions only.

Movement Capabilities

Type Movement	Movement	
	Inch	mm
Compression	1	25
Elongation	1	25
Transverse Deflection (at recommended installed position)	± 1	± 25

Movements are non-concurrent.

Type Movement	Pipe I.D.		Max. Allowed
	Inch	mm	
Angular Deflection (at recommended installed position)	2	50	35°
	2-1/2 to 3	63 to 75	30°
	4	100	25°
	5 to 6	125 to 150	20°
	8	200	15°
	10 to 12	250 to 300	10°

Style 9394

This multi-convoluted, lightweight expansion joint is designed for lower pressure applications that require significant amounts of movement, axially and/or laterally. Its low spring rates make it ideal for load cell applications.

Benefits

- Lightweight design installs easily, costs less to ship
- Can be custom-designed for even greater movement capability
- Choice of construction materials suitable for wide range of temperatures
- Available in flanged or sleeve type design, up to 48" max. (1,219 mm) I.D. *Contact Garlock for larger ID sizes

Note: Flanged designs require retaining rings for an effective seal. Sleeve type requires clamps; the overall length of the expansion joint should include an additional 4" (101.6 mm) for clamping space.

Pressure

- Without external reinforcing rings: up to 3 psi (0.2 bar)
- With external reinforcing rings: up to 15 psi (1.0 bar)

Vacuum

- Without internal reinforcing rings: up to 3 inches (75 mm) Hg
- With internal reinforcing rings: up to 15 inches (381 mm) Hg

Contact Garlock if higher vacuum or pressure ratings are required.

Movement Capabilities

Type Movement	Pipe Size		Movement	
	Inch	mm	Inch	mm
Compression	2-6	50-150	3/4	19
	8-10	200-250	7/8	22
	12-18	300-450	1-1/8	28
	20-Up	500-Up	1-5/8	41
Elongation	2-6	50-150	5/8	16
	8-10	200-250	3/4	19
	12-18	300-450	1	25
	20-Up	500-Up	1-1/4	31
Lateral	2-6	50-150	5/8	16
	8-10	200-250	3/4	19
	12-18	300-450	1	25
	20-Up	500-Up	1-1/4	31

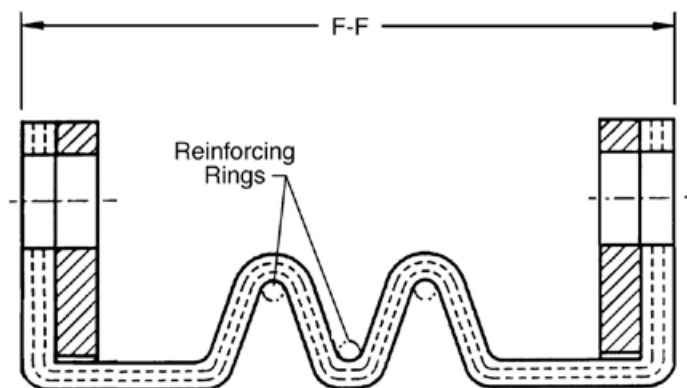

Cross Section of Style 9394 with Reinforcing Rings

Alternate Tube and Cover Materials

- Neoprene
- Nitrile
- Hypalon*
- Natural Gum
- EPDM
- Viton*

Temperature

Standard Materials **Max. Temp.**
 Chlorobutyl/polyester w/ Natural Gum. +180°F (+82°C)
 Chlorobutyl/polyester..... +250°F (+120°C)
 Chlorobutyl/fiberglass/Kevlar* +300°F (+150°C)
 Fluoroelastomer/fiberglass/Kevlar +400°F (+205°C)

* Kevlar is a registered trademark of DuPont;
 Viton and Hypalon are registered trademarks of DuPont Dow Elastomers.

Style 8400 Flue Ducts

Garlock offers a wide range of flue duct type expansion joints for lightweight applications, especially for scrubbers, precipitators, baghouses, and fans in air handling systems. Style 8400 flue ducts are available in round, rectangular or square configurations, as belt type (without flanges) or U-type (flanged), with virtually no size restrictions.

Garlock also provides on-site vulcanization for flue ducts that require splicing into position due to obstructions or interferences that prevent continuous construction installations.



Rectangular / Square

- Face-to-face dimensions: typically 6" (152 mm), 9" (229 mm), 12" (305 mm) or 16" (406 mm)
- If any leg is smaller than 30" (762 mm), joint will be built on a metal form with column corners
- Consult factory for movement capabilities

Note: Other sizes also available.

If more movement is required, please contact Garlock.

Round

- Supplied in any size, with or without flanges or arch
- Variety of materials available: neoprene chlorobutyl, fluoroelastomer, nitrile, EPDM, Hypalon*, white neoprene, white EPDM or natural/gum rubber.
- Movement capabilities depend on expansion joint size and arch configuration

Belt Type

- Supplied in any size, without flanges, with or without an arch
- Available in the same materials as round flue ducts
- Movement capabilities depend on installation width and arch configuration
- Supplied open-ended (wraparound), or continuous to fit over ducting

Temperature

Style No.	Standard Robus Materials	Max. Temp.
8400-250	Neoprene/fiberglass/Kevlar**	+250°F (+120°C)
8400-300	Chlorobutyl/fiberglass/Kevlar	+300°F (+150°C)
8400-400	Fluoroelastomer/fiberglass/ Kevlar	+400°F (+205°C)

Made in the U.S.A.

* Hypalon is a registered trademark of DuPont Dow Elastomers.

** Kevlar is a registered trademark of DuPont.

Style 8400-HT / High Temperature Flue Ducts

In typical Garlock fashion, the 8400-HT will be custom designed to meet or exceed the individual requirements of each application or system design specifications. The 8400-HT is available in a multitude of configurations and material combinations, complimenting our existing 8400 family of lower temperature products (8400-250, 8400-300, 8400-400). The 8400-HT is able to accommodate operating temperatures as low as -75°F (-60°F) up to 2200°F (1200°C).

Benefits

Specific combinations of fluorine based hydrocarbon polymers and reinforcing materials offer an unusually high resistance to corrosive substances at high temperatures, ideal for most operating conditions in flue gas desulphurization systems (FGD);

- Very good rebound characteristics that help resist permanent deformation
- Special resistance to SO_2 , H_2SO_4 and other corrosive chemical substances
- Continuous operating temperature in excess of 400°F

Ideal for

In addition to FGD systems non metallic, flue duct style expansion joints, are commonly used in gaseous media such as hot air, chemical vapors, engine exhaust, etc. For example:

- Steam boiler systems
- Gas Turbine Exhausts
- Industrial furnace & chimney construction
- Refuse incinerators
- Ventilation and aeration systems
- HPI, CPI emissions control
- Pulp & Paper industry

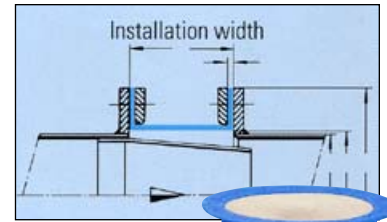
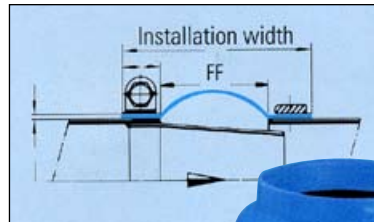
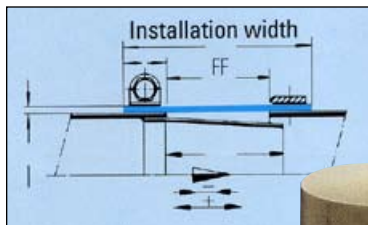

The illustrated types can be used in different applications with different material make-up, but with the same design and movement absorption.

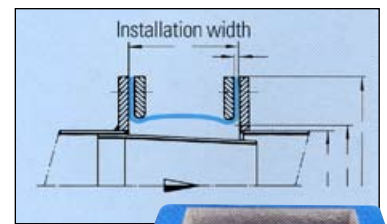
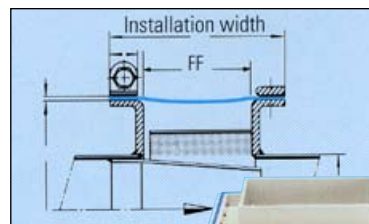
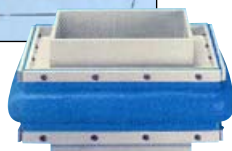
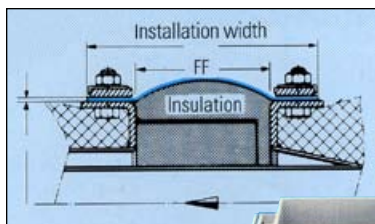

Style 8420 Split

Easy installation and removal reduce downtime with new split expansion joint

Garlock offers a wide range of flue duct type expansion joints for lightweight applications, especially for scrubbers, precipitators, baghouses, and fans in air handling systems. Style 8400 flue ducts are available in round, rectangular or square configurations, as belt type (without flanges) or U-type (flanged), with virtually no size restrictions.

Garlock also provides on-site vulcanization for flue ducts that require splicing into position due to obstructions or interferences that prevent continuous construction installations.

- Split design eliminates equipment disassembly, reducing costly downtime
- Available in EPDM, nitrile* and fluoroelastomer in sizes from 2" to 24" standard. Contact Garlok for larger sizes
- Can be customized for your application; contact Garlock with your specifications
- Adhesive kits with comprehensive installation instructions are provided with every shipment to facilitate quick assembly

* EPDM and nitrile are standard— other elastomers available on request.



Unassembled View

Specifications

	2" Max. Pipe Gap Opening	4" Max. Pipe Gap Opening	6" Max. Pipe Gap Opening
Clamps Required:	4	4	4
Thickness:			
2"-12" Size (50.8 mm-304.8 mm)	1/4" (6.4 mm)	1/4" (6.4 mm)	1/4" (6.4 mm)
14"-24" Size (355.6 mm-609.6 mm)	3/8" (9.5 mm)	3/8" (9.5 mm)	3/8" (9.5 mm)
Pressure, Max.:	15 psi (1.034 bar)	5 psi (0.345 bar)	5 psi (0.345 bar)
Vacuum:	14" Hg (356 mm Hg)	5" Hg (127 mm Hg)	5" Hg (127 mm Hg)
Temperature, Max.:	400°F (204°C)	400°F (204°C)	400°F (204°C)
Movement:	Vibration Only	Vibration Only	Vibration Only
Lateral Misalignment, Max.:	1/2" (12.7 mm)	1/2" (12.7 mm)	1/2" (12.7 mm)
Width of Joint:	8" (203.2 mm)	8" (203.2 mm)	10" (254 mm)

Notes:

1. All applications above 165°F (74°C) require Viton* adhesive kits.
2. T-bolt clamps recommended on all applications; not included with adhesive kits.

* Viton is a registered trademark of DuPont Dow Elastomers.

Navy and Coast Guard

Navy

Garlock manufactures numerous expansion joints in accordance with U.S. Navy specifications.

Style 9278 EZ-FLO® is designed to meet the requirements of ASTM F1123, and is constructed of neoprene and polyamide. Retaining rings must be galvanized in accordance with the specification. Hydrostatic testing may be required and is performed in-house at our Palmyra, New York, facility.

Style 7706 S-type (as pictured) has been developed specifically for submarine service.

Other styles are available per application. Consult the factory for specific designs.



Coast Guard

Garlock expansion joints that can be certified to Coast Guard Specification ASTM-F1123 are:

- Style 206 EZ-FLO®
- Style 204 CL 11
- GARFLEX® 8100

All of these styles must have a neoprene cover (with no paint). Coast Guard certification should be requested at the time of quotation or order.



WARNING:

Properties/applications shown throughout this brochure are typical. Your specific application should not be undertaken without independent study and evaluation for suitability. For specific application recommendations consult Garlock. Failure to select the proper sealing products could result in property damage and/or serious personal injury.

Performance data published in this brochure has been developed from field testing, customer field reports and/or in-house testing.

While the utmost care has been used in compiling this brochure, we assume no responsibility for errors. Specifications subject to change without notice. This edition cancels all previous issues. Subject to change without notice.

GARLOCK is a registered trademark for packings, seals, gaskets, and other products of Garlock.

Technical Data

Sizes • Dimensions • Movements • Standard 150# Drilling

Joint Size (Inside Dia.) ¹	1	1 1/4	1 1/2	2	2 1/2	3	4	5	6	8	10	12	14	16	18	20	22	24	26	28	30	34	36
Flange Outside Dia.	4 1/4	4 5/8	5	6	7	7 1/2	9	10	11	13 1/2	16	19	21	23 1/2	25	27 1/2	29 1/2	32	34 1/4	36 1/2	38 3/4	43 3/4	46
Bolt Circle Dia.	3 7/8	3 1/2	3 7/8	4 3/4	5 1/2	6	7 1/2	8 1/2	9 1/2	11 3/4	14 1/4	17	18 3/4	21 1/4	22 3/4	25	27 1/4	29 1/2	31 3/4	34	36	40 1/2	42 3/4
Number Bolt Holes	4	4	4	4	4	4	8	8	8	8	12	12	12	16	16	20	20	20	24	28	28	32	32
Diameter Bolt Holes	5/8	5/8	5/8	3/4	3/4	3/4	3/4	7/8	7/8	7/8	1	1	1 1/8	1 1/8	1 1/4	1 1/4	1 3/8	1 3/8	1 3/8	1 3/8	1 3/8	1 5/8	1 5/8
Single Arch Recom. FF	6	6	6	6	6	6	6	6	6	6	8	8	8	8	8	8	10	10	10	10	10	10	10
204	Dimensions Flg. Thk. A	1/2	1/2	1/2	1/2	1/2	1/2	1/2	1/2	1/2	1/2	1/2	1/2	1/2	1/2	1/2	1/2	1/2	5/8	5/8	5/8	5/8	5/8
	Arch Ht. B	1	1	1 1/4	1 1/4	1 1/4	1 1/4	1 1/4	1 1/4	1 1/2	1 1/2	1 1/2	2	2	2	2	2	2	2 1/4	2 1/4	2 1/4	2 1/4	2 1/4
	Arch Width C	1/2	1/2	1/2	1/2	1/2	1/2	1/2	1/2	3/4	3/4	3/4	3/4	3/4	3/4	7/8	7/8	7/8	1	1	1	1	1
	Single Arch Min. FF	5 1/2	5 1/2	5 1/2	5 1/2	5 1/2	5 1/2	5 1/2	5 1/2	5 1/2	7	7	7	7	7	7	9	9	9	9	9	9	9
	Double Arch Min. FF	9	9	9	9	9	9	9	9	9	10	10	10	11 3/4	11 3/4	11 3/4	12 3/4	12 3/4	12 3/4	12 3/4	12 3/4	12 3/4	12 3/4
Triple Arch Min. FF	12	12	12	12	12	12	12	12	12	14	14	14	15 1/2	15 1/2	15 1/2	16 3/4	16 3/4	16 3/4	16 3/4	16 3/4	16 3/4	16 3/4	
	R	3/8	3/8	3/8	3/8	3/8	3/8	3/8	3/8	3/8	3/8	3/8	3/8	3/8	3/8	3/8	3/8	3/8	3/8	3/8	3/8	3/8	
204, 204HP, 200, 200HP																							
Max. Axial Compression	1/4	1/4	1/4	1/2	1/2	1/2	1/2	1/2	1/2	3/4	3/4	3/4	3/4	3/4	3/4	7/8	7/8	7/8	1	1	1	1	1
Max. Lateral Deflection	1/4	1/4	1/4	1/2	1/2	1/2	1/2	1/2	1/2	1/2	1/2	1/2	1/2	1/2	1/2	1/2	1/2	1/2	1/2	1/2	1/2	1/2	
Max. Axial Elongation	1/8	1/8	1/8	1/4	1/4	1/4	1/4	1/4	1/4	3/8	3/8	3/8	3/8	3/8	3/8	7/16	7/16	7/16	1/2	1/2	1/2	1/2	
206 EZ-FLO®, G306 EZ-FLO®																							
Dimensions Flg. Thk. A	1/2	1/2	1/2	1/2	1/2	1/2	1/2	1/2	1/2	1/2	1/2	1/2	1/2	1/2	1/2	1/2	1/2	1/2	5/8	5/8	5/8	5/8	
Wall Thk. B	3/8	3/8	3/8	3/8	3/8	3/8	3/8	3/8	9/16	9/16	5/8	5/8	5/8	5/8	5/8	5/8	5/8	5/8	13/16	13/16	13/16	13/16	
206 EZ-FLO®, G306 EZ-FLO®																							
Max. Axial Compression	3/4	3/4	3/4	3/4	3/4	3/4	3/4	3/4	1	1	1	1	1	1	1	1 1/8	1 1/8	1 1/8	1 1/4	1 1/4	1 1/4	1 1/4	
Max. Lateral Deflection	1/2	1/2	1/2	1/2	1/2	1/2	1/2	1/2	1/2	1/2	1/2	1/2	1/2	1/2	1/2	1/2	1/2	1/2	1/2	1/2	1/2	1/2	
Max. Axial Elongation	3/8	3/8	3/8	3/8	3/8	3/8	3/8	3/8	1/2	1/2	1/2	1/2	1/2	1/2	1/2	1/2	1/2	1/2	1/2	1/2	1/2	1/2	

All specifications in inches unless otherwise noted.

Styles 200, 200HP, 204, 204HP

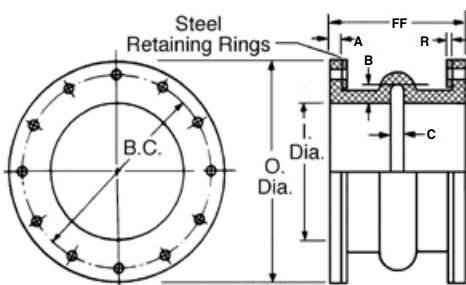

Styles 206, 306 EZ-FLO®

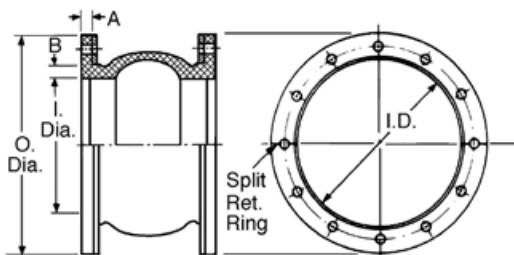

204 Single Arch Movements

Size (Inches)	Angular Movement (Degrees)	Torsional Movement (Degrees)
2	14.5	3
3	10	3
4	7.5	3
5	6	3
6-8	5	3
10-12	4	3
14-16	2.5	2
18-30	2	1
34-54	1.5	1
56-96	1	1

Note: The degree of angular movement is based on the max. extension shown.

WARNING:

Properties/applications shown throughout this brochure are typical. Your specific application should not be undertaken without independent study and evaluation for suitability. For specific application recommendations consult Garlock. Failure to select the proper sealing products could result in property damage and/or serious personal injury.

Performance data published in this brochure has been developed from field testing, customer field reports and/or in-house testing.

While the utmost care has been used in compiling this brochure, we assume no responsibility for errors. Specifications subject to change without notice. This edition cancels all previous issues. Subject to change without notice.

Pressure Ratings

Style 204 / GUARDIAN® 200

Pressure and vacuum service

Pipe Size I.D.		Pressure		Vacuum	
Inches	mm	psi	bar	In. Hg	mm Hg
1/2-4	13-100	165	11	29.9	750
5-12	125-300	140	10	29.9	750
14	350	85	6	29.9	750
16-24	400-600	65	4.5	29.9	750
26-66	650-1650	55	3.8	29.9	750
68-96	1700-2400	45	3	29.9	750
98-108	2450-2700	40	2.8	29.9	750
110-120	2750-3000	30	2	29.9	750

Style 204HP / GUARDIAN® 200HP

High pressure and vacuum service

Pipe Size I.D.		Pressure		Vacuum	
Inches	mm	psi	bar	In. Hg	mm Hg
1/2-4	13-100	200	14	29.9	750
8-12	200-300	190	13	29.9	750
14	350	130	9	29.9	750
16-20	400-500	110	8	29.9	750
22-24	550-600	100	7	29.9	750
26-40	650-1000	90	6	29.9	750
42-66	1050-1650	80	5.5	29.9	750
68-96	1700-2400	70	5	29.9	750
98-108	2450-2700	60	4	29.9	750
110-120	2750-3000	50	3.5	29.9	750

Style 206 EZ-FLO®

High pressure service

Pipe Size I.D.		Pressure		Vacuum	
Inches	mm	psi	bar	In. Hg	mm Hg
2-10	50-250	250	17	26	650
12	300	250	17	12	300
14	350	130	9	12	300
16-20	400-500	110	8	12	300
22-24	550-600	100	7	12	300
26-40	650-1000	90	6	12	300
42-66	1050-1650	80	5.5	12	300
68-96	1700-2400	70	5	12	300
98-108	2450-2700	60	4	12	300
110-120	2750-3000	50	3.5	12	300

Notes:

- See pages B-6 and B-7 for temperature and pressure ratings of GUARDIAN® 306 EZ-FLO® expansion joint.
- Pressure and vacuum ratings at neutral FF dimension. Extended face-to-face dimensions result in reduced pressure and vacuum ratings for Style 206 EZ-FLO® expansion joints.

	ID	40	42	48	50	54	60	66	72	78	84	90	96	108	120
OD	50 ³ / ₄	53	59 ¹ / ₂	61 ³ / ₄	66 ¹ / ₄	73	80	86 ¹ / ₂	93	99 ³ / ₄	106 ¹ / ₂	113 ¹ / ₄	126 ³ / ₄	140 ¹ / ₄	
ØBC	47 ¹ / ₄	49 ¹ / ₂	56	58 ³ / ₄	62 ³ / ₄	69 ¹ / ₄	76	82 ¹ / ₂	88 ³ / ₄	95 ¹ / ₂	102	108 ¹ / ₂	120 ³ / ₄	132 ³ / ₄	
#BH	36	36	44	44	44	52	52	60	60	64	68	68	72	76	
ØBH	1 ⁵ / ₈	1 ⁵ / ₈	1 ⁵ / ₈	1 ⁷ / ₈	2	2	2	2	2 ¹ / ₈	2 ¹ / ₄	2 ³ / ₈	2 ¹ / ₂	2 ¹ / ₂	2 ¹ / ₂	
FF	10	12	12	12	12	12	12	12	12	12	12	12	12	12	
A	5 ⁹ / ₈	7 ⁷ / ₈	7 ⁷ / ₈	7 ⁷ / ₈	7 ⁷ / ₈	7 ⁷ / ₈	7 ⁷ / ₈	1 ¹ / ₄	1 ¹ / ₄	1 ¹ / ₄	1 ¹ / ₄	1 ¹ / ₄	1 ¹ / ₄	1 ¹ / ₄	1 ³ / ₈
B	2 ¹ / ₄	2 ¹ / ₂	2 ¹ / ₂	2 ¹ / ₂	2 ¹ / ₂	2 ¹ / ₂	2 ¹ / ₂	2 ¹ / ₂	2 ¹ / ₂	2 ¹ / ₂	2 ¹ / ₂	2 ¹ / ₂	2 ¹ / ₂	2 ¹ / ₂	2 ¹ / ₂
C	1	1 ¹ / ₈	1 ¹ / ₈	1 ¹ / ₈	1 ¹ / ₈	1 ¹ / ₈	1 ¹ / ₈	1 ¹ / ₈	1 ¹ / ₈	1 ¹ / ₈	1 ¹ / ₈	1 ¹ / ₈	1 ¹ / ₈	1 ¹ / ₈	1 ¹ / ₈
FF	9	10	10	10	10	10	10	10	10	10	10	10	10	10	
FF	14	14	14	14	14	14	14	15 ¹ / ₂	15 ¹ / ₂	15 ¹ / ₂	15 ¹ / ₂	15 ¹ / ₂	15 ¹ / ₂	15 ¹ / ₂	15 ¹ / ₂
FF	17 ¹ / ₂	17 ¹ / ₂	17 ¹ / ₂	17 ¹ / ₂	17 ¹ / ₂	17 ¹ / ₂	17 ¹ / ₂	17 ¹ / ₂	17 ¹ / ₂	17 ¹ / ₂	17 ¹ / ₂	17 ¹ / ₂	17 ¹ / ₂	17 ¹ / ₂	17 ¹ / ₂
R	3 ³ / ₈	3 ³ / ₈	3 ³ / ₈	3 ³ / ₈	3 ³ / ₈	3 ³ / ₈	1	3 ³ / ₈	3 ³ / ₈	3 ³ / ₈	3 ³ / ₈	3 ³ / ₈	3 ³ / ₈	3 ³ / ₈	3 ³ / ₈
204															
C	1	1 ¹ / ₈	1 ¹ / ₈	1 ¹ / ₈	1 ¹ / ₈	1 ¹ / ₈	1 ¹ / ₈	1 ¹ / ₈	1 ¹ / ₈	1 ¹ / ₈	1 ¹ / ₈	1 ¹ / ₈	1 ¹ / ₈	1 ¹ / ₈	1 ¹ / ₈
L	1/2	1/2	1/2	1/2	1/2	1/2	1/2	1/2	1/2	1/2	1/2	1/2	1/2	1/2	1/2
E	1/2	1/2	1/2	1/2	1/2	1/2	1/2	1/2	1/2	1/2	1/2	1/2	1/2	1/2	1/2
A	5 ⁷ / ₈	7 ⁷ / ₈	7 ⁷ / ₈	7 ⁷ / ₈	7 ⁷ / ₈	7 ⁷ / ₈	7 ⁷ / ₈	1 ¹ / ₄	1 ¹ / ₄	1 ¹ / ₄	1 ¹ / ₄	1 ¹ / ₄	1 ¹ / ₄	1 ¹ / ₄	1 ³ / ₈
B	1 ³ / ₁₆	1	1	1	1	1	1 ³ / ₈	1 ³ / ₈	1 ³ / ₈	1 ³ / ₈	1 ³ / ₈	1 ³ / ₈	1 ³ / ₈	1 ³ / ₈	1 ¹ / ₂
206															
C	1 ¹ / ₄	1 ³ / ₈	1 ³ / ₈	1 ³ / ₈	1 ³ / ₈	1 ³ / ₈	1 ³ / ₈	1 ³ / ₈	1 ³ / ₈	1 ³ / ₈	1 ³ / ₈	1 ³ / ₈	1 ³ / ₈	1 ³ / ₈	1 ³ / ₈
L	1/2	1/2	1/2	1/2	1/2	1/2	1/2	1/2	1/2	1/2	1/2	1/2	1/2	1/2	1/2
E	1/2	1/2	1/2	1/2	1/2	1/2	1/2	1/2	1/2	1/2	1/2	1/2	1/2	1/2	1/2

Notes:

- Pipe sizes through 1¹/₂" are supplied with a filled arch (Style 204, 204HP), and movements have been reduced accordingly. Open-arch construction is available on special order.
- Pressure/vacuum ratings are for standard FF dimensions only. Consult Garlock for non-standards.
- For shorter "FF" dimensions, consult Garlock.
- Forces to compress, deflect and elongate elastomeric expansion joints are based on ambient temperature and zero pressure in the pipeline. These forces should be considered only as approximate and may vary with the elastomers and fabric used in construction. To convert force in pounds to kilograms, divide by 2.205.
- Movement of multiple-arch joints can be determined by multiplying the number of arches by the single-arch values in the table above.
- For filled-arch joints, reduce the axial compression, elongation and transverse deflection value by 50%.
- Rated movements are non-concurrent.
- Control units are recommended for most applications.

Drilling Specifications

ANSI B16.1 1975 Class 125
 ANSI B16.24 1971 Class 150
 ANSI B16.5 1973 Class 150
 MSS SP-51 1965 MSS 150 lb.
 AWWA C201 Class B
Note: Special drillings available.

Types of Expansion Joints

Single Arch

- Fabric and rubber construction
- Reinforced with metal/wire rings
- Full-face flanges integral with joint body
- Flanges drilled to companion bolt pattern
- Gaskets not required

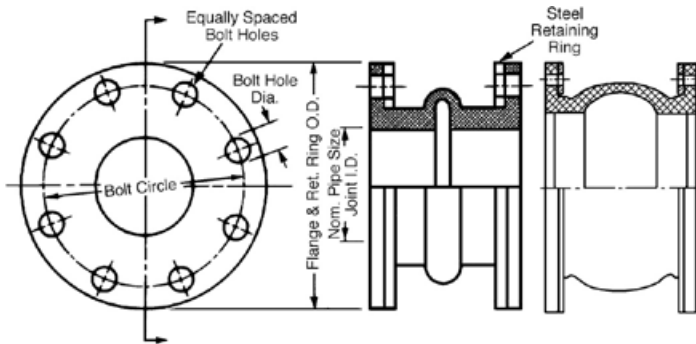

Offset

- Compensates for initial misalignment and non-parallelism of piping axis
- Custom-built to your specifications
- Complete drawings and specifications recommended with inquiries/orders

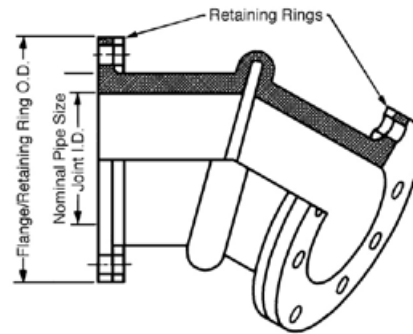

Multiple Arch

- Accommodates greater movement than single arch
- Minimum joint length depends on number of arches
- Maximum of four arches recommended to maintain lateral stability

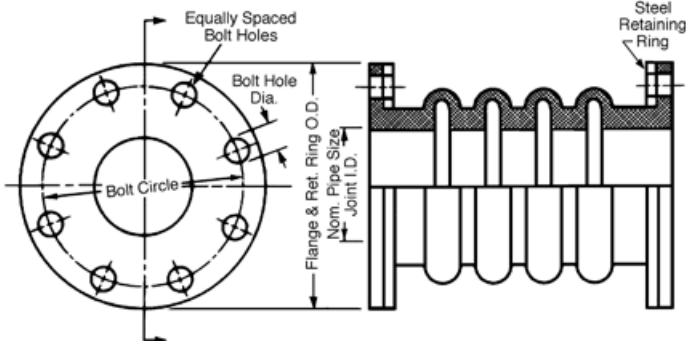

Sleeve

- Same as single arch type, except sleeve end I.D. equals pipe O.D.
- Slips over straight ends of open pipe
- Ends secured by suitable clamps
- Recommended for low pressure service only

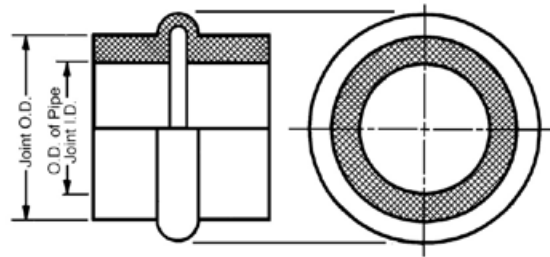

Taper or Reducer

- Connects piping of different diameters
- Concentric tapered joints: same axis for both ends
- Eccentric: axis of one end offset from other end
- Tapers in excess of 15° are not recommended

- Pressure ratings are based on larger I.D.
- Available with or without arches

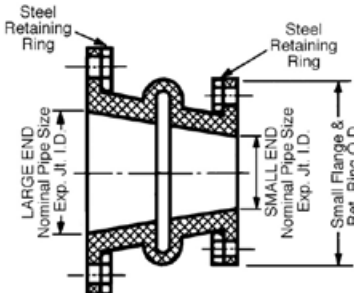

Concentric Taper

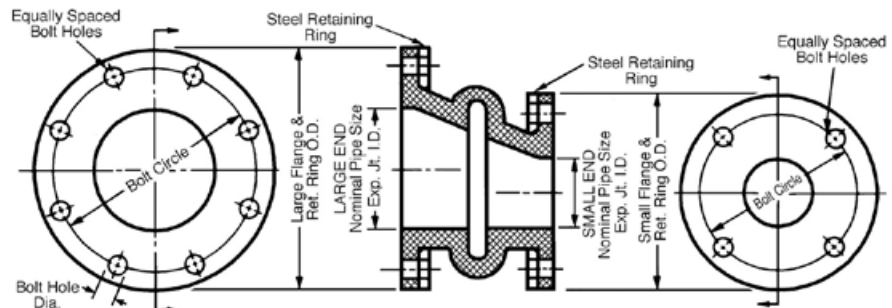

Eccentric Taper

Expansion Joint Components

Tube

- Synthetic or natural rubber forms seamless, leak-proof lining
- Extends fully through bore to outer flange edge
- Common materials include chlorobutyl, neoprene, natural rubber, EPDM, Viton* and Hypalon*

Body or Carcass

- When wrapped or plied, reinforcements provide support and flexibility between tube and cover
- Fabric reinforcement: polyester or other suitable fabrics impregnated with specified elastomers
- Metal reinforcement: bonded rectangular steel rings exclusive to Garlock, or continuous strands of wire and round steel body rings
- Metal reinforcement rings provide longer service life, extra safety protection, and extra rigidity, allowing higher pressure ratings

Cover

- Homogeneous layer of synthetic or natural rubber
- Chlorobutyl is standard; other elastomers available to meet your specific applications
- Rubber or other weather-resistant coating protects carcass from corrosion or damage

Metal Retaining Rings

- Must be used in all applications; provides metal surface to distribute bolting pressure equally, preventing flange damage during bolt tightening
- Install behind and against inner face of each flange
- Standard material: mild steel with corrosion-resistant coating; galvanized or stainless steel also available

Metal Flow Liners

- Extends service life by providing protection from abrasive materials or solids, especially in high velocity applications
- Flanged at one end, installed at the head of the flow, tapered to a 5° angle, allows lateral deflection
- Liner flange thickness: 10 gauge
Liner body thickness: 12 gauge

- Available in 304/316 stainless steel; also: titanium, Hastelloy C**
- Special metal liner configurations also available for reducing or multiple arch design. Contact Garlock.

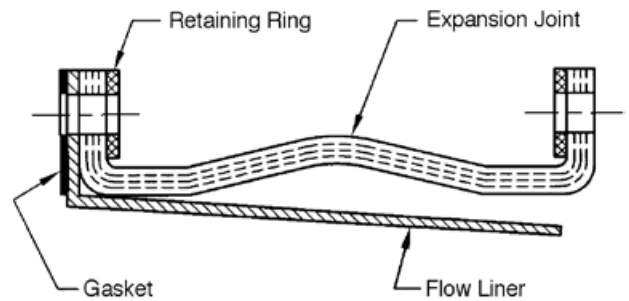

Metal Flow Liner Installation

Control Units

- Recommended on most applications to prevent damage due to excessive pipe movement
- Consists of two or more tie rods connected between flanges
- Triangular end plate has two holes for bolting plate securely to flange, and one hole to accommodate plate connecting tie rod
- Rubber washer between plate and rod substantially reduces both noise and vibration
- Installing pipe sleeves over tie rods provides additional protection against overcompression damage
- NOT designed to replace pipeline anchoring

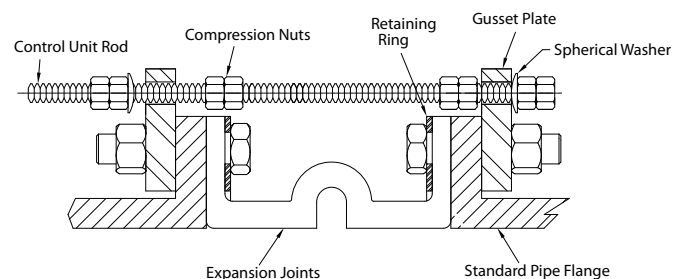

Typical Control Unit for Rubber Expansion Joint

Types of Pipe Movements

Axial Compression

- Longitudinal movement shortens face-to-face dimension along axis of expansion joint or flexible coupling
- Pipe flanges remain perpendicular to axis

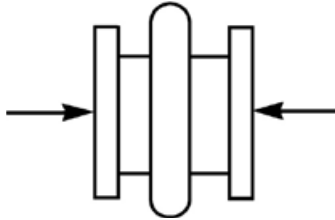

Lateral/Transverse Movement

- Offset movement of one or both pipe flanges
- Both flanges remain parallel to each other while forming angle to axis of joint

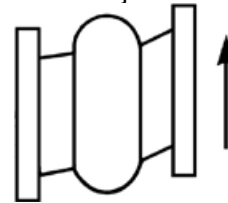

Axial Elongation

- Longitudinal movement lengthens face-to-face dimension along axis of expansion joint or flexible coupling
- Pipe flanges remain perpendicular to axis

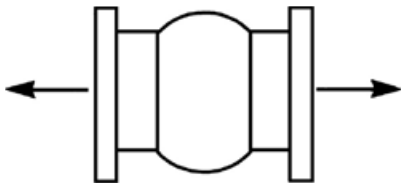

Angular Movement

- Deflection or rotation of one or both flanges
- Forms angle with axis of expansion joint or flexible coupling

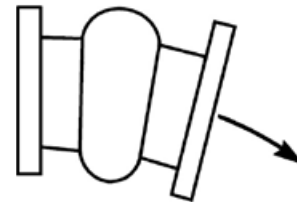

Torsional Movement

- Rotation of one flange with stationary counterpart
- Simultaneous rotation of both flanges in opposing motion

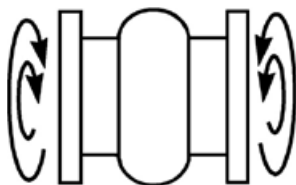

Vibration

- Oscillating movement around axis of expansion joint or flexible coupling
- Pipe flanges remain parallel with each other
- Flanges remain perpendicular to axis
- Mechanical vibration in steel piping system reduced with installation of pipe connectors or expansion joints



Typical Properties of Elastomers

Material Designation		Rating Scale Code	Elastomer Physical and Chemical Properties Comparison									
ANSI / ASTM D1418-77	ASTM D-2000 D1418-77	7 - Outstanding 3 - Fair to Good 6 - Excellent 2 - Fair 5 - Very Good 1 - Poor to Fair 4 - Good 0 - Poor X - Contact Manufacturer	Water Chemical Animal & Vegetable Oil Alkali, Condensed	Alkali, Dilute Oil & Gasoline Lacquers Oxygenated Hydrocarbons	Aromatic Hydrocarbons Aliphatic Hydrocarbons Acid, Concentrated Acid, Dilute	Swelling in Oil Radiation Water Absorption Electrical Insulation	Dielectric Strength Tensile Strength Compression Set Rebound, Cold	Rebound, Hot Dynamic Impermeability Abrasion	Tear Flame Cold Heat	Oxidation Sunlight Weather Ozone		
		COMMON NAME Chemical Group Name										
CR	BC BE	NEOPRENE chloroprene	4 3 4 0	4 4 0 1	2 3 4 6	4 5 4 3	5 4 2 4	5 2 4 5	4 4 4 4	5 5 6 5		
NR	AA	GUM RUBBER polyisoprene, synthetic	5 3 X X	X 0 0 4	0 0 3 3	0 6 5 5	6 6 4 6	6 6 2 7	5 0 5 2	4 0 2 0		
IR	AA	NATURAL RUBBER polyisoprene, synthetic	5 3 X X	X 0 0 4	0 0 3 3	0 6 5 5	6 6 4 6	6 2 2 6	5 0 5 2	4 0 2 0		
IIR	AA	BUTYL isobutene-isoprene	5 6 5 4	4 0 3 4	0 0 4 6	0 4 5 5	5 4 3 0	5 2 6 4	4 0 4 5	6 5 5 6		
CIIR	AA BA	CHLOROBUTYL chloro-isobutene-isoprene	5 6 5 4	4 0 3 4	0 0 4 6	0 4 5 5	5 4 3 0	5 2 6 4	4 0 4 5	6 5 5 6		
NBR	BE BK CH	BUNA-N / NITRILE nitrile-butadiene	4 3 5 0	4 5 2 0	4 6 4 4	5 5 4 1	0 5 5 4	4 5 4 4	3 0 3 4	4 0 2 2		
SBR	AA	SBR / GRS / BUNA-S styrene-butadiene	5 3 X 2	4 0 0 4	0 0 3 3	0 6 5 5	4 5 4 4	4 4 2 5	3 0 5 3	2 0 2 0		
CSM	CE	HYPALON* chloro-sulfonyl-polyethylene	5 6 4 4	4 4 3 1	2 3 4 6	4 5 4 3	5 2 2 2	4 2 4 4	3 4 4 4	6 7 6 7		
FKM	HK	VITON* / FLUOREL** fluorocarbon elastomer	5 6 6 0	4 6 1 0	6 6 6 5	6 5 5 3	5 5 6 2	4 5 5 5	2 6 2 7	7 7 7 7		
EPR	BA CA DA	EPDM ethylene-propylene- diene-terpolymer	5 6 5 6	6 0 3 6	0 0 4 6	0 7 6 6	7 5 4 6	6 5 4 5	4 0 5 6	6 7 6 7		
AFMU		TEFLON† / TFE / FEP fluoro-ethylene-polymers	7 7 7 7	7 7 7 7	7 7 7 7	7 3 7 X	X X X X	X X X 4	X X X 7	7 7 7 7		
S	GE	SILICONE	5 5 5 0	2 X 0 2	0 0 2 6	2 5 6 6	4 0 3 6	6 0 2 0	2 3 6 7	6 6 6 6		

Temperature Ratings

Body Material

Max. Temp.

Chlorobutyl/polyester.....	+250°F (+120°C)
Chlorobutyl/nylon tire cord.....	+250°F (+120°C)
Chlorobutyl/fiberglass/Kevlar† with EPDM tube and cover.....	+300°F (+150°C)
Fluoroelastomer/fiberglass/Kevlar.....	+400°F (+205°C)

Liner and/or Cover Material

Max. Temp.

EPDM.....	+300°F (+150°C)
FEP fluorocarbon.....	+400°F (+205°C)
Fluoroelastomer.....	+400°F (+205°C)
HNBR (hydrogenated nitrile).....	+300°F (+150°C)
Hypalon.....	+250°F (+120°C)
Natural/gum.....	+180°F (+80°C)
Neoprene.....	+250°F (+120°C)
Nitrile.....	+250°F (+120°C)
PTFE.....	+450°F (+230°C)

* Hypalon and Viton are registered trademarks of DuPont Dow Elastomers.

** Fluorel is a registered trademark of 3M Companies.

† Teflon and Kevlar are registered trademarks of DuPont.

WARNING:

Properties/applications shown throughout this brochure are typical. Your specific application should not be undertaken without independent study and evaluation for suitability. For specific application recommendations consult Garlock. Failure to select the proper sealing products could result in property damage and/or serious personal injury.

Performance data published in this brochure has been developed from field testing, customer field reports and/or in-house testing.

While the utmost care has been used in compiling this brochure, we assume no responsibility for errors. Specifications subject to change without notice. This edition cancels all previous issues. Subject to change without notice.

GARLOCK is a registered trademark for packings, seals, gaskets, and other products of Garlock.

Expansion Joint Installation

Preparation

Check service range

- Double check performance limits against anticipated operating conditions
- Check temperature, pressure, vacuum recommendations
- Check total joint deflection—alter as needed to reduce deflection to correct range
- Anchor lines

Check location

- Proper location is usually close to main anchoring point
- Install pipe guide(s) for proper alignment
- Joint should absorb pipeline expansion / contraction between fixed anchor points

Check cover

- Check outside joint cover for damage
- Cover will keep harmful materials from penetrating joint carcass

Check alignment

- Alignment should be 0.125" (3.2 mm) or less
- If 0.125" (3.2mm) must be exceeded, use a special offset joint

Check support

- Weight must not be carried by joint
- Support with hangers or anchors

Check flanges

- Clean all mating flanges
- Do not gouge or mutilate surfaces during cleaning
- Carefully examine used parts for smoothness

Installation

Apply lubricant

- On elastomeric joints only, not required with all PTFE- or FEP-lined joints
- Coat rubber faces with graphite in water, or glycerine, to prevent joint adherence to pipe flanges

Insert bolts from arch side

- On elastomeric joints only, not necessary with PTFE joints/couplings with threaded holes
- Set bolt heads adjacent to arch

Tighten bolts

- Elastomeric joints only, tighten gradually and equally, alternating around flange
- Edges of joint must bulge slightly at flange O.D.

Check tightness

- Within one week after application, then periodically
- In hot or cold water systems during cyclical changes

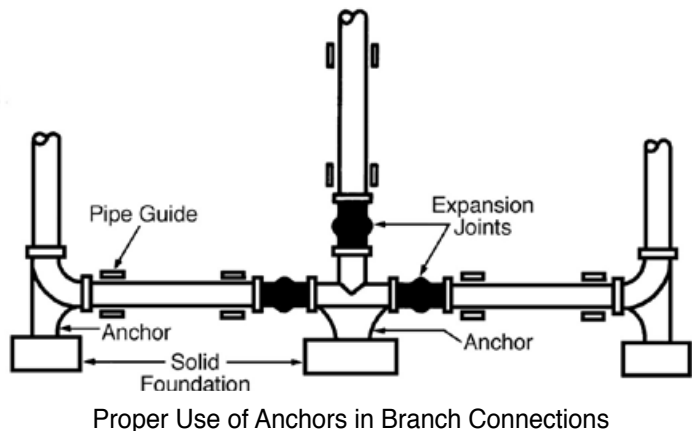
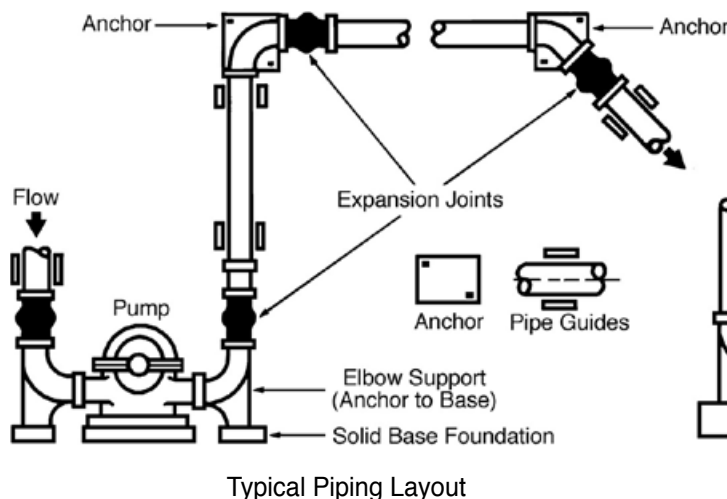

Troubleshooting

General Precautions

Elastomeric Joints Only

- Use proper care breaking seal
- Drive flanges apart gently with wooden wedges
- Bring insulation only to pipe flange—do not insulate over or around joint
 - Covering joints may make leak detection difficult
 - Insulation could restrict joint movement or cause overheating
- Store in cool, dry, dark area
- Do not rest on flange edges
- Carefully protect joints near welding operations
- Never install spool-type joints next to flangeless check valves or butterfly valves
- Install only against full-face metal flanges or damage/leakage could result; restrictions also apply to raised face or any non-full face flange

Flange leakage

- Check bolt tightness
- Check mating flange surface area for:
 - Grooves
 - Scratches
 - Distorted areas
- Over-extension may indicate need for control units

Liquid weeping from bolt holes

- Check tube portion of joint for leaks; replace if necessary

Cracking at base of arch or flange

- Check installed face-to-face dimensions for over-extension or over-compression
- Check for proper pipe alignment: must not exceed 0.125" (3.2mm)

Excessive ballooning of arch

- Indicates distortion/deterioration of joint strengthening members, or excessive system pressure
- Re-evaluate service conditions
- Install new joint



WARNING:

Properties/applications shown throughout this brochure are typical. Your specific application should not be undertaken without independent study and evaluation for suitability. For specific application recommendations consult Garlock. Failure to select the proper sealing products could result in property damage and/or serious personal injury.

Performance data published in this brochure has been developed from field testing, customer field reports and/or in-house testing.

While the utmost care has been used in compiling this brochure, we assume no responsibility for errors. Specifications subject to change without notice. This edition cancels all previous issues. Subject to change without notice.

GARLOCK is a registered trademark for packings, seals, gaskets, and other products of Garlock.

Expansion Joint Weights*

For Rubber Spool-Type Joints, and Styles 200 and 204

Joint Size (Inches)	Approx Lbs per Joint				Approx. Lbs / Set	
	Face to-Face Dimension				Retaining Rings	Control Units
6 Inches	8 Inches	10 Inches	12 Inches			
2	3.5	4.0	—	—	3.5	5.5
2-1/2	4.0	5.0	—	—	5.0	6.5
3	4.5	5.5	—	—	5.5	6.5
3-1/2	5.5	6.6	—	—	6.5	6.5
4	6.5	7.8	—	—	6.8	5.5
5	7.5	9.5	—	—	7.5	10.5
6	8.8	11.5	13.8	15.5	8.8	10.5
8	12.5	15.0	20.0	22.0	12.5	10.5
10	16.0	23.5	25.0	28.0	15.8	22
12	—	28.8	35.0	41.5	23.5	22
14	—	38.0	45.0	53.0	25.5	29
16	—	48.0	52.0	60.0	31.0	29
18	—	50.0	55.0	68.0	29.5	29
20	—	55.0	67.0	78.0	36.0	26
24	—	—	77.0	91.0	46.0	33
26	—	—	92.0	110.0	50.0	52
28	—	—	110.0	120.0	60.0	52
30	—	—	118.0	130.0	63.0	58
34	—	—	128.0	140.0	82.0	76
36	—	—	140.0	152.0	85.0	76
42	—	—	—	222.0	113.0	115
48	—	—	—	252.0	138.0	150
54	—	—	—	275.0	157.0	162
60	—	—	—	337.0	180.0	298
72	—	—	—	365.0	260.0	361
78	—	—	—	405.0	280.0	301
84	—	—	—	430.0	320.0	393



* For total approximate weights, add the weight of the expansion joint at the required face-to-face dimension to the weight of retaining rings and/or control units.

Example (Metrics):

A 100 mm joint (200 mm face-to-face) with retaining rings equals 3.5 Kg. + 3.1 Kg., or 6.6 Kg. A 350 joint (250 mm face-to-face) with retaining rings and control units equals 20.4 Kg. + 11.6 Kg. + 12.2 Kg., or 44.2 Kg.

To convert pounds to kilograms, divide by 2.205.

Note: For calculating weight of Style 206 EZ-FLO® expansion joint = Style 204 x 0.66.

For PTFE Couplings, with Flanges and Restricting Bolts

	Pipe Size (Inches)								
	1	1-1/2	2	2-1/2	3	4	5	6	8
Style 214	2 lbs.	4 lbs.	7 lbs.	10 lbs.	12 lbs.	18 lbs.	24 lbs.	29 lbs.	47 lbs.
Style 215	2 lbs.	4 lbs.	8 lbs.	11 lbs.	13 lbs.	19 lbs.	25 lbs.	30 lbs.	47 lbs.

WARNING:

Properties/applications shown throughout this brochure are typical. Your specific application should not be undertaken without independent study and evaluation for suitability. For specific application recommendations consult Garlock. Failure to select the proper sealing products could result in property damage and/or serious personal injury.

Performance data published in this brochure has been developed from field testing, customer field reports and/or in-house testing.

While the utmost care has been used in compiling this brochure, we assume no responsibility for errors. Specifications subject to change without notice. This edition cancels all previous issues. Subject to change without notice.

GARLOCK is a registered trademark for packings, seals, gaskets, and other products of Garlock.

Application Data Form

For quotation or application recommendations, simply copy this page, fill it out entirely and mail or fax it to Garlock or to your local authorized distributor.

Name: _____	Date: _____
Phone No.: _____	Company: _____
	Fax No.: _____
Pipe Size: _____	Control Units?: _____
Temperature: _____	Hydrostatic Testing?: _____
Pressure/Vacuum: _____	Replacement?: For What Style?: _____
Media: _____	Comments: _____
Movements - Compression: _____	_____
Elongation: _____	_____
Lateral: _____	_____
Face-to-Face Dimension: _____	_____
Drilling (if other than 125/150 lb.): _____	_____
Retaining Rings: _____	_____

More than just great products...

Beyond offering you the widest available range of products for packing and sealing, Garlock enhances the value of its products with technical services and comprehensive training programs:

- ISO 9001:2000 registration for Industrial Gasketing, Industrial Packing, KLOZURE® Oil Seals, Bearing Protectors, and Mechanical Seals, Expansion Joints, Hydraulic Components, and Industrial Rubber Products.
- A global network of stocking Authorized Garlock Distributors.
- Factory sales representatives and applications engineers available for problem solving when and where it is needed.
- Toll-free 800 telephone and fax numbers for immediate product information.
- In-plant surveys of equipment and processes, providing the customer with recommendations to identify and eliminate sealing and packing problems before they start.
- The most sophisticated and most comprehensive test facilities available.
- Technical field seminars on all Garlock products.
- Factory-sponsored product training programs, including hands-on seminars, to ensure that Garlock representatives and their distributor personnel are the best in the industry.
- Technical Bulletins to keep you up-to-date on product enhancements and changes.

Customers who specify Garlock fluid sealing products get, at no extra cost, the high quality support needed to run a profitable operation.

AUTHORIZED REPRESENTATIVE

WARNING:

Properties/applications shown throughout this brochure are typical. Your specific application should not be undertaken without independent study and evaluation for suitability. For specific application recommendations consult Garlock. Failure to select the proper sealing products could result in property damage and/or serious personal injury.

Performance data published in this brochure has been developed from field testing, customer field reports and/or in-house testing.

While the utmost care has been used in compiling this brochure, we assume no responsibility for errors. Specifications subject to change without notice. This edition cancels all previous issues. Subject to change without notice.

GARLOCK is a registered trademark for packings, seals, gaskets, and other products of Garlock.

© Garlock Inc 2008. All rights reserved worldwide.

Garlock
SEALING TECHNOLOGIES®

an EnPro Industries company

Garlock Sealing Technologies
1666 Division Street
Palmyra, New York 14522 USA
+1.315.597.4811
Toll Free 1.800.448.6688
Toll Free Fax: 1.800.543.0598
+1.315.597.3039

www.garlock.com

Other Garlock facilities are located in:

Columbia, SC, USA	Phone +1.803.783.1880	Fax +1.803.783.4279
Houston, TX, USA	Phone +1.281.840.4800	Fax +1.281.840.4756
Sydney, Australia	Phone +61.2.9793.2511	Fax +61.2.9793.2544
São Paulo, Brazil	Phone +55.11.4352.6161	Fax +55.11.4352.8181
Sherbrooke, Canada	Phone +1.819.563.8080	Fax +1.819.563.5620
W. Yorkshire, England	Phone +44.1422.313600	Fax +44.1422.313601
Saint-Étienne, France	Phone +33.4.7743.5100	Fax +33.4.7743.5151
Neuss, Germany	Phone +49.2131.3490	Fax +49.2131.349.222
Mexico City, Mexico	Phone +52.55.50.78.46.00	Fax +52.555.368.0418
Singapore	Phone +65.6285.9322	Fax +65.6284.5843
Shanghai, China	Phone +86.021.62789702	Fax +86.021.62787826
Dubai, UAE	Phone +971.4.8833652	Fax +971.4.8833682
Pune, India	Phone +91.20.3061.6608	Fax +91.20.3061.6699